

**JIC male x JIC male BULKHEAD 90°  
forged compact elbow**

Nov-21  
1013 IMP

All dimensions are imperial unless stated.

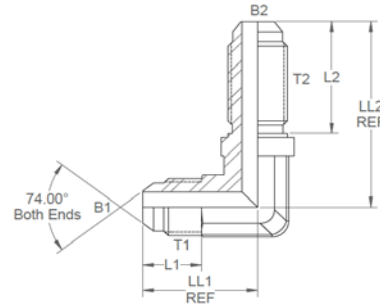

	T1	T2	B1	B2	L1	L2	LL1	LL2	A/F
10525-03	3/8	3/8	0.125	0.125	0.464	0.92	0.94	1.5	0.438
10525-04	7/16	7/16	0.172	0.172	0.535	1.02	0.97	1.59	0.438
10525-04-06	7/16	9/16	0	0	0	0	0	0	0
10525-05	1/2	1/2	0.234	0.234	0.535	1.02	1.06	1.72	0.562
10525-06	9/16	9/16	0.297	0.297	0.541	1.09	1.09	1.81	0.562
10525-08	3/4	3/4	0.391	0.391	0.642	1.25	1.36	2.11	0.75
10525-10	7/8	7/8	0.484	0.484	0.743	1.39	1.56	2.39	0.875
10525-12	1-1/16	1-1/16	0.609	0.609	0.849	1.56	1.78	2.67	1.062
10525-16	1-5/16	1-5/16	0.844	0.844	0.896	1.56	1.94	2.8	1.312
10525-20	1-5/8	1-5/8	1.078	1.078	0.943	1.61	2.17	3.12	1.625

DESIGN DETAILS AND SPECIFICATIONS SUBJECT TO CHANGE WITHOUT PRIOR NOTICE - Whilst every effort has been made to ensure the accuracy of the information supplied herein, Burnett & Hillman cannot be held responsible for any errors or omissions (E&OE)

## JIC male x JIC male BULKHEAD 90° forged compact elbow

Nov-21  
1013 METRIC

A/F dimensions are imperial unless stated.

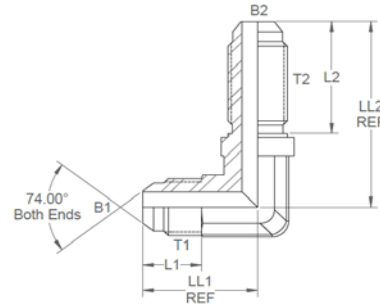

	T1	T2	B1	B2	L1	L2	LL1	LL2	A/F
10525-03	3/8	3/8	3.18	3.18	11.79	23.37	23.88	38.1	0.438
10525-04	7/16	7/16	4.37	4.37	13.59	25.91	24.64	40.39	0.438
10525-04-06	7/16	9/16	0	0	0	0	0	0	0
10525-05	1/2	1/2	5.94	5.94	13.59	25.91	26.92	43.69	0.562
10525-06	9/16	9/16	7.54	7.54	13.74	27.69	27.69	45.97	0.562
10525-08	3/4	3/4	9.93	9.93	16.31	31.75	34.54	53.59	0.75
10525-10	7/8	7/8	12.29	12.29	18.87	35.31	39.62	60.71	0.875
10525-12	1-1/16	1-1/16	15.47	15.47	21.56	39.62	45.21	67.82	1.062
10525-16	1-5/16	1-5/16	21.44	21.44	22.76	39.62	49.28	71.12	1.312
10525-20	1-5/8	1-5/8	27.38	27.38	23.95	40.89	55.12	79.25	1.625