

All dimensions are imperial unless stated.

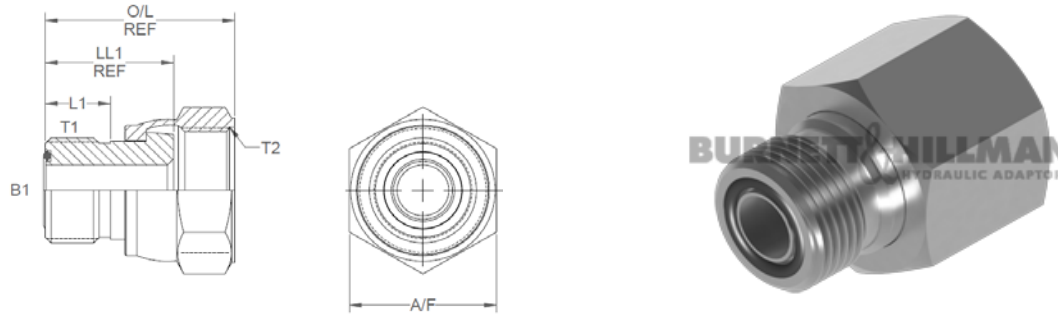

	T1	T2	B1	L1	LL1	O/L	A/F
9015-04-06AS	9/16	11/16	0.172	0.386	0.77	1.11	0.812
9015-04-12AS	9/16	1-3/16	0.172	0.386	0.98	1.51	1.375
9015-06-08AS	11/16	13/16	0.264	0.441	0.88	1.31	0.938
9015-06-12AS	11/16	1-3/16	0.264	0.441	1.03	1.54	1.375
9015-08-10AS	13/16	1	0.378	0.504	1.01	1.48	1.125
9015-10-12AS	1	1-3/16	0.484	0.61	1.16	1.73	1.375
9015-12-16AS	1-3/16	1-7/16	0.609	0.67	1.3	1.88	1.625
9015-16-20AS	1-7/16	1-11/16	0.811	0.689	1.514	2.05	1.875

A/F dimensions are imperial unless stated.

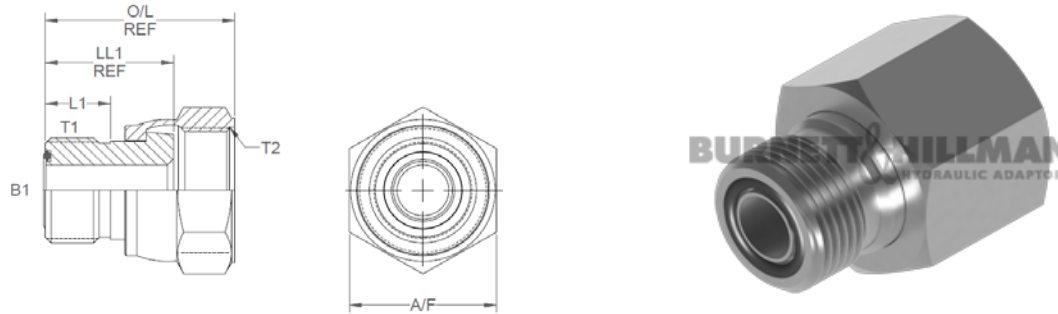

	T1	T2	B1	L1	LL1	O/L	A/F
9015-04-06AS	9/16	11/16	4.37	9.8	19.56	28.19	0.812
9015-04-12AS	9/16	1-3/16	4.37	9.8	24.89	38.35	1.375
9015-06-08AS	11/16	13/16	6.71	11.2	22.35	33.27	0.938
9015-06-12AS	11/16	1-3/16	6.71	11.2	26.16	39.12	1.375
9015-08-10AS	13/16	1	9.6	12.8	25.65	37.59	1.125
9015-10-12AS	1	1-3/16	12.29	15.49	29.46	43.94	1.375
9015-12-16AS	1-3/16	1-7/16	15.47	17.02	33.02	47.75	1.625
9015-16-20AS	1-7/16	1-11/16	20.6	17.5	38.46	52.07	1.875