

All dimensions are imperial unless stated.

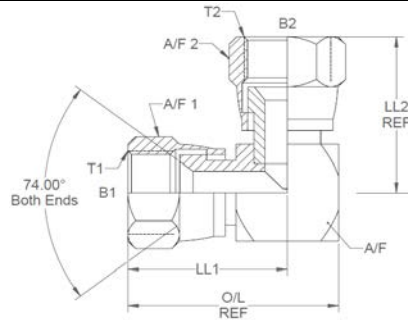

	T1	T2	B1	B2	O/L	LL1	LL2	A/F	A/F1	A/F2
05075	7/16	7/16	0.176	0.176	1.217	0.967	0.935	0.5	0.562	0.562
05076	1/2	1/2	0.203	0.203	1.433	1.1	0.97	0.5	0.625	0.625
05077	9/16	9/16	0.297	0.297	1.431	1.091	1.088	0.625	0.687	0.687
05078	3/4	3/4	0.39	0.39	1.815	1.382	1.406	0.875	0.875	0.875
05079	7/8	7/8	0.5	0.5	2.08	1.579	1.565	0.875	1	1
05080	1-1/16	1-1/16	0.593	0.593	2.39	1.763	1.738	1.125	1.25	1.25
05082	1-3/16	1-3/16	0.75	0.75	2.612	1.96	1.82	1.375	1.375	1.375
05081	1-5/16	1-5/16	0.812	0.812	2.895	2.076	1.919	1.375	1.5	1.5
05083	1-5/8	1-5/8	1.078	1.078	3.102	2.202	2.2	1.75	50mm	50mm
05084	1-7/8	1-7/8	1.25	1.25	3.573	2.51	2.445	2	55mm	55mm

**JIC swivel female x JIC swivel female
90° compact elbow**

Oct-21
0624 METRIC

A/F dimensions are imperial unless stated.

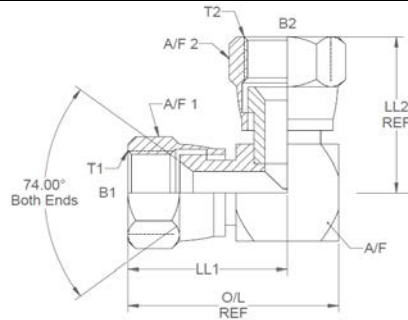

	T1	T2	B1	B2	O/L	LL1	LL2	A/F	A/F1	A/F2
05075	7/16	7/16	4.47	4.47	30.91	24.56	23.75	0.5	0.562	0.562
05076	1/2	1/2	5.16	5.16	36.4	27.94	24.64	0.5	0.625	0.625
05077	9/16	9/16	7.54	7.54	36.35	27.71	27.64	0.625	0.687	0.687
05078	3/4	3/4	9.91	9.91	46.101	35.1	35.71	0.875	0.875	0.875
05079	7/8	7/8	12.7	12.7	52.83	40.11	39.75	0.875	1	1
05080	1-1/16	1-1/16	15.06	15.06	60.71	44.78	44.15	1.125	1.25	1.25
05082	1-3/16	1-3/16	19.05	19.05	66.34	49.78	46.23	1.375	1.375	1.375
05081	1-5/16	1-5/16	20.62	20.62	73.53	52.73	48.74	1.375	1.5	1.5
05083	1-5/8	1-5/8	27.38	27.38	78.79	55.93	55.88	1.75	50mm	50mm
05084	1-7/8	1-7/8	31.75	31.75	90.75	63.75	62.1	2	55mm	55mm