

All dimensions are imperial unless stated.

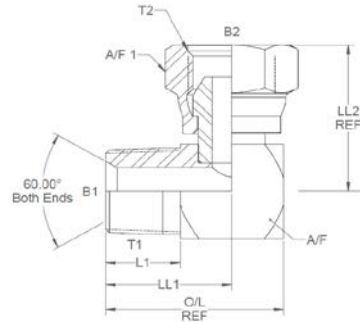

	T1	T2	B1	B2	L1	O/L	LL1	LL2	A/F	A/F1
09397	1/8	1/8	0.188	0.125	0.38	0.88	0.63	0.8	0.5	14mm
09393	1/8	1/4	0.188	0.172	0.515	1.14	0.827	1.09	0.625	19mm
09400	1/4	1/4	0.25	0.172	0.625	1.312	0.962	0.96	0.625	19mm
09401	3/8	3/8	0.375	0.271	0.69	1.465	1.077	1.163	0.75	22mm
09402	1/2	1/2	0.472	0.375	0.84	1.84	1.34	1.277	0.875	27mm
09403	3/4	3/4	0.687	0.6	0.95	2.1	1.525	1.48	1.125	32mm
09404	1	1	0.843	0.797	1.25	2.75	2	1.7	1.375	41mm
09398	1-1/4	1-1/4	1.203	1.014	1.5	3.3	2.4	1.96	1.75	50mm
09399	1-1/2	1-1/2	1.312	1.201	1.6	3.65	2.625	2.35	2	55mm

A/F dimensions are imperial unless stated.

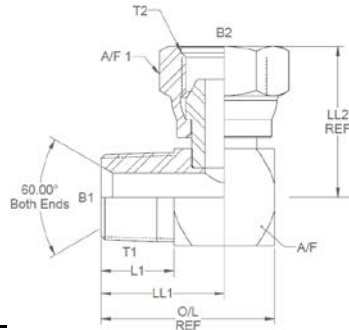

	T1	T2	B1	B2	L1	O/L	LL1	LL2	A/F	A/F1
09397	1/8	1/8	4.78	3.18	9.65	22.35	16	20.32	0.5	14mm
09393	1/8	1/4	4.78	4.37	13.08	28.96	21.01	27.69	0.625	19mm
09400	1/4	1/4	6.35	4.37	15.88	33.32	24.43	24.38	0.625	19mm
09401	3/8	3/8	9.53	6.88	17.53	37.21	27.36	29.54	0.75	22mm
09402	1/2	1/2	11.99	9.53	21.34	46.74	34.04	32.44	0.875	27mm
09403	3/4	3/4	17.45	15.24	24.13	53.34	38.74	37.59	1.125	32mm
09404	1	1	21.41	20.24	31.75	69.85	50.8	43.18	1.375	41mm
09398	1-1/4	1-1/4	30.56	25.76	38.1	83.82	60.96	49.78	1.75	50mm
09399	1-1/2	1-1/2	33.32	30.51	40.64	92.71	66.68	59.69	2	55mm