

All dimensions are imperial unless stated.

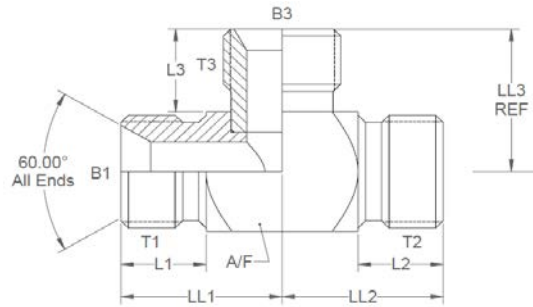

	T1	T2	T3	B1	B3	L1	L2	L3	LL1	LL2	LL3	A/F
01901	1/4	1/4	1/4	0.185	0.185	0.45	0.45	0.47	0.832	0.832	0.782	0.625
01902	3/8	3/8	3/8	0.312	0.312	0.52	0.52	0.56	0.99	0.99	0.935	0.75
01903	1/2	1/2	1/2	0.437	0.437	0.6	0.6	0.6	1.135	1.135	1.037	0.875
01905	3/4	3/4	3/4	0.625	0.625	0.75	0.75	0.75	1.482	1.482	1.312	1.125
01906	1	1	1	0.812	0.812	0.8	0.8	0.84	1.737	1.737	1.527	1.375
01908	1-1/2	1-1/2	1-1/2	1.312	1.312	0.85	0.85	0.85	2.225	2.225	1.85	2
01909	2	2	2	1.75	1.75	1	1	1	2.65	2.65	2.25	2.5

A/F dimensions are imperial unless stated.

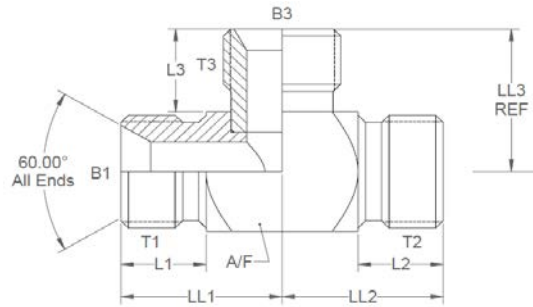

	T1	T2	T3	B1	B3	L1	L2	L3	LL1	LL2	LL3	A/F
01901	1/4	1/4	1/4	4.7	4.7	11.43	11.43	11.94	21.13	21.13	19.86	0.625
01902	3/8	3/8	3/8	7.92	7.92	13.21	13.21	14.22	25.15	25.15	23.75	0.75
01903	1/2	1/2	1/2	11.1	11.1	15.24	15.24	15.24	28.83	28.83	26.34	0.875
01905	3/4	3/4	3/4	15.88	15.88	19.05	19.05	19.05	37.64	37.64	33.32	1.125
01906	1	1	1	20.62	20.62	20.32	20.32	21.34	44.12	44.12	38.79	1.375
01908	1-1/2	1-1/2	1-1/2	33.32	33.32	21.59	21.59	21.59	56.52	56.52	46.99	2
01909	2	2	2	44.45	44.45	25.4	25.4	25.4	67.31	67.31	57.15	2.5