

All dimensions are imperial unless stated.

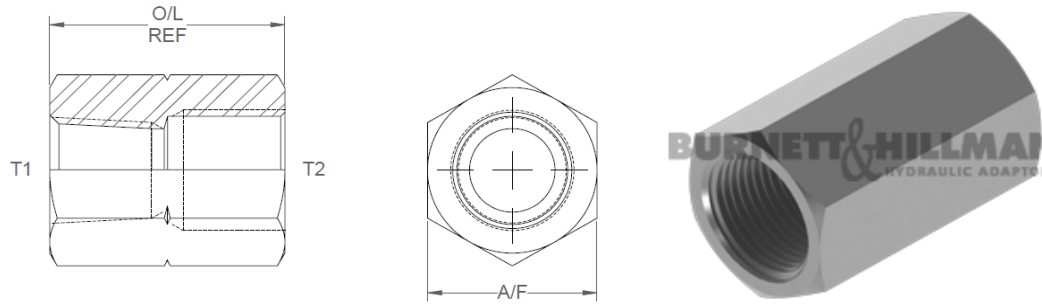

	T1	T2	O/L	A/F
90101	1/4	M12 x 1.5	1.155	19mm
90102	1/4	M14 x 1.5	1.155	19mm
90103	1/4	M16 x 1.5	1.2	22mm

A/F dimensions are imperial unless stated.

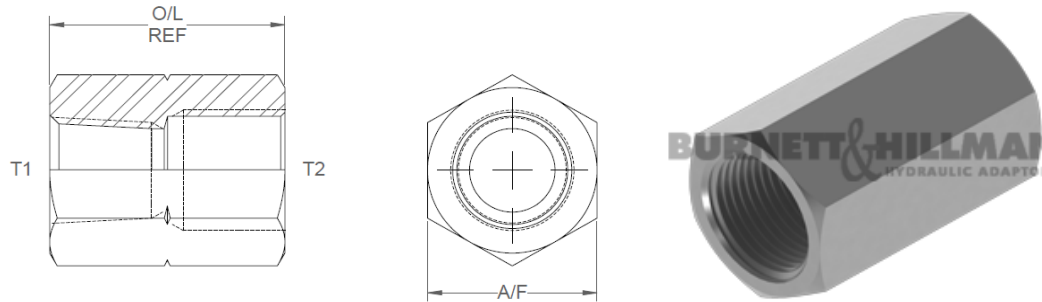

	T1	T2	O/L	A/F
90101	1/4	M12 x 1.5	29.34	19mm
90102	1/4	M14 x 1.5	29.34	19mm
90103	1/4	M16 x 1.5	30.48	22mm