

All dimensions are imperial unless stated.

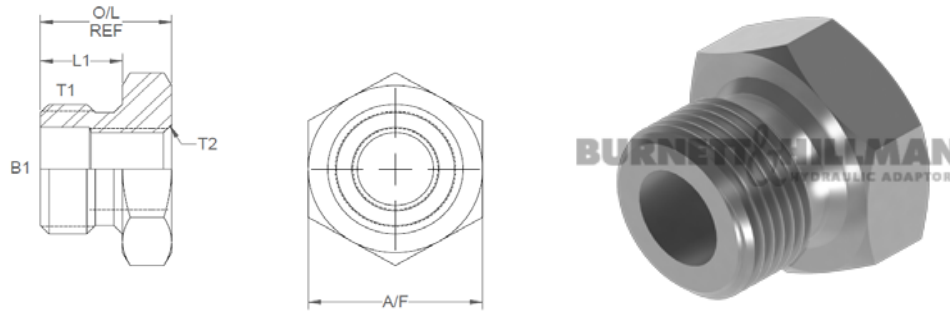

	T1	T2	B1	L1	O/L	A/F
00780	3/8	1/8	0.345	0.45	0.73	22mm
00781	1/2	1/8	0.41	0.5	0.8	1.01
00782	1/2	1/4	0.53	0.5	0.8	27mm
00783	5/8	1/4	0.464	0.55	0.91	30mm
00784	5/8	3/8	0.6	0.55	0.91	30mm
00785	3/4	1/8	0.393	0.54	0.9	32mm
00786	3/4	1/4	0.53	0.54	0.9	32mm
00787	3/4	3/8	0.68	0.54	0.9	32mm
00788	1	1/4	0.464	0.64	1.04	41mm
00789	1	3/8	0.68	0.64	1.04	1.67
00790	1	1/2	0.75	0.64	1.04	41mm
00791	1	5/8	0.828	0.64	1.04	41mm
00792	1-1/4	1/4	0.464	0.75	1.2	50mm
00793	1-1/4	3/8	0.6	0.75	1.2	50mm
00794	1-1/4	1/2	0.75	0.75	1.2	50mm
00795	1-1/4	3/4	0.964	0.75	1.2	50mm
00796	1-1/4	1	1.21	0.75	1.2	50mm
00797	1-1/2	1/4	0.464	0.75	1.3	55mm
00798	1-1/2	3/8	0.6	0.75	1.3	55mm
00799	1-1/2	1/2	0.75	0.75	1.3	55mm

DESIGN DETAILS AND SPECIFICATIONS SUBJECT TO CHANGE WITHOUT PRIOR NOTICE - Whilst every effort has been made to ensure the accuracy of the information supplied herein, Burnett & Hillman cannot be held responsible for any errors or omissions (E&OE)

All dimensions are imperial unless stated.

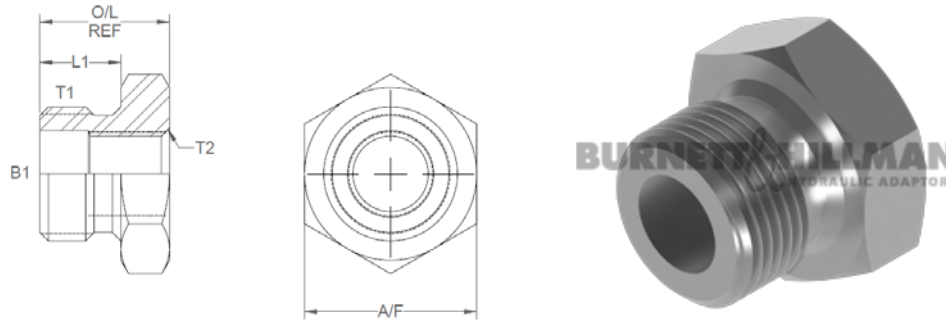

	T1	T2	B1	L1	O/L	A/F
00800	1-1/2	5/8	0.828	0.75	1.3	2.22
00801	1-1/2	3/4	0.964	0.75	1.3	55mm
00802	1-1/2	1	1.21	0.75	1.3	55mm
00803	2	1/4	0.464	1	1.7	70mm
00804	2	3/8	0.6	1	1.7	70mm
00805	2	1/2	0.75	1	1.7	70mm
00806	2	5/8	0.828	1	1.7	70mm
00807	2	3/4	0.964	1	1.7	70mm
00808	2	1	1.21	1	1.7	70mm
00809	2	1-1/4	1.555	1	1.7	70mm
00810	2	1-1/2	1.781	1	1.7	70mm
00811	4	1-1/2	1.781	1	1.8	4.75

A/F dimensions are imperial unless stated.

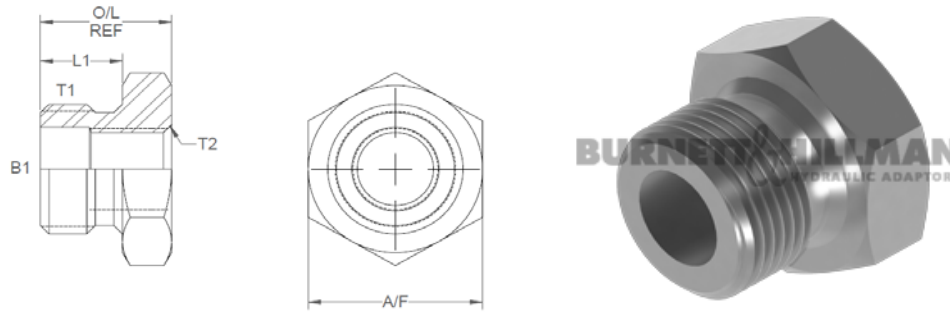

	T1	T2	B1	L1	O/L	A/F
00780	3/8	1/8	8.76	11.43	18.54	22mm
00781	1/2	1/8	10.41	12.7	20.32	1.01
00782	1/2	1/4	13.46	12.7	20.32	27mm
00783	5/8	1/4	11.79	13.97	23.11	30mm
00784	5/8	3/8	15.24	13.97	23.11	30mm
00785	3/4	1/8	9.98	13.72	22.86	32mm
00786	3/4	1/4	13.46	13.72	22.86	32mm
00787	3/4	3/8	17.27	13.72	22.86	32mm
00788	1	1/4	11.79	16.26	26.42	41mm
00789	1	3/8	17.27	16.26	26.42	1.67
00790	1	1/2	19.05	16.26	26.42	41mm
00791	1	5/8	21.03	16.26	26.42	41mm
00792	1-1/4	1/4	11.79	19.05	30.48	50mm
00793	1-1/4	3/8	15.24	19.05	30.48	50mm
00794	1-1/4	1/2	19.05	19.05	30.48	50mm
00795	1-1/4	3/4	24.49	19.05	30.48	50mm
00796	1-1/4	1	30.73	19.05	30.48	50mm
00797	1-1/2	1/4	11.79	19.05	33.02	55mm
00798	1-1/2	3/8	15.24	19.05	33.02	55mm
00799	1-1/2	1/2	19.05	19.05	33.02	55mm

DESIGN DETAILS AND SPECIFICATIONS SUBJECT TO CHANGE WITHOUT PRIOR NOTICE - Whilst every effort has been made to ensure the accuracy of the information supplied herein, Burnett & Hillman cannot be held responsible for any errors or omissions (E&OE)

A/F dimensions are imperial unless stated.

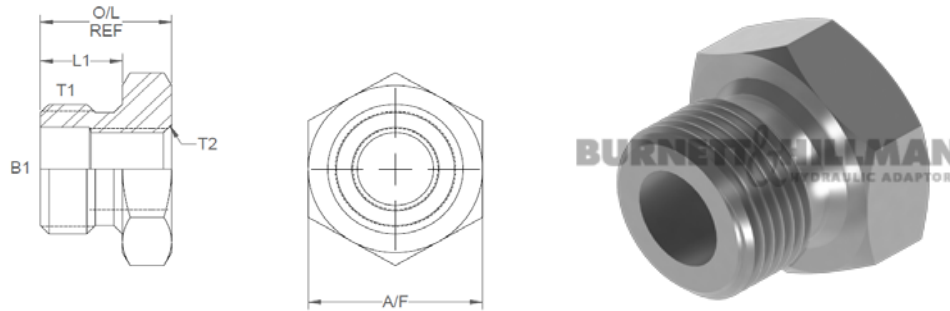

	T1	T2	B1	L1	O/L	A/F
00800	1-1/2	5/8	21.03	19.05	33.02	2.22
00801	1-1/2	3/4	24.49	19.05	33.02	55mm
00802	1-1/2	1	30.73	19.05	33.02	55mm
00803	2	1/4	11.79	25.4	43.18	70mm
00804	2	3/8	15.24	25.4	43.18	70mm
00805	2	1/2	19.05	25.4	43.18	70mm
00806	2	5/8	21.03	25.4	43.18	70mm
00807	2	3/4	24.49	25.4	43.18	70mm
00808	2	1	30.73	25.4	43.18	70mm
00809	2	1-1/4	39.5	25.4	43.18	70mm
00810	2	1-1/2	45.24	25.4	43.18	70mm
00811	4	1-1/2	45.24	25.4	45.72	4.75