

All dimensions are imperial unless stated.

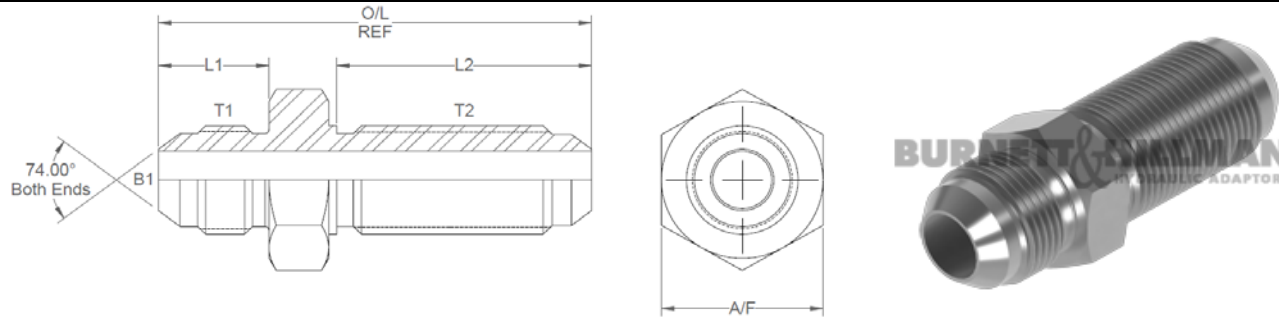

	T1	T2	B1	L1	L2	O/L	A/F
00192	3/8	3/8	0.125	0.479	1.1	1.9	0.625
00180	7/16	7/16	0.172	0.55	1.2	2.07	0.687
00181	1/2	1/2	0.234	0.55	1.2	2.07	19mm
00182	9/16	9/16	0.297	0.556	1.28	2.18	0.812
00183	3/4	3/4	0.391	0.657	1.44	2.44	1
00184	7/8	7/8	0.484	0.758	1.58	2.74	1.125
00185	1-1/16	1-1/16	0.609	0.864	1.75	3.09	1.375
00186	1-3/16	1-3/16	0.719	0.89	1.75	3.12	1.5
00187	1-5/16	1-5/16	0.844	0.911	1.75	3.14	41mm
00188	1-5/8	1-5/8	1.078	0.958	1.8	3.31	1.875
00189	1-7/8	1-7/8	1.312	1.083	1.81	3.52	55mm
00193	2-1/2	2-1/2	1.781	1.333	2.09	4.2	70mm

**JIC male x JIC male bulkhead LESS
LOCKNUT**

Nov-21
0129 METRIC

A/F dimensions are imperial unless stated.

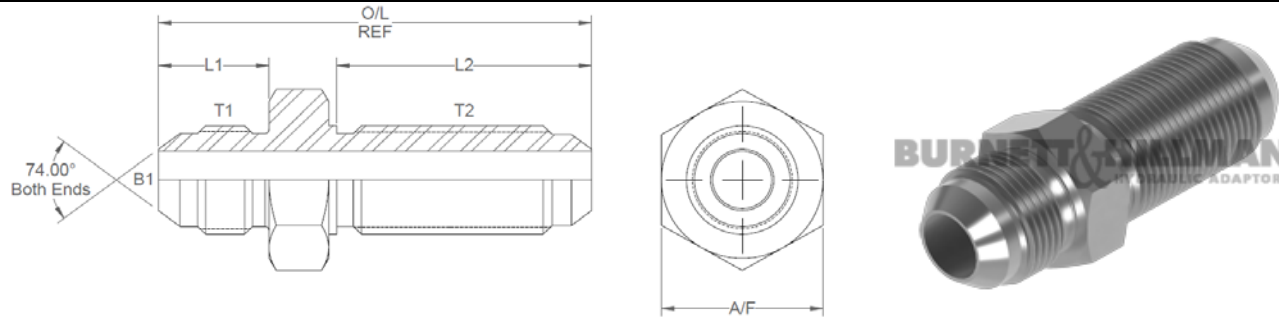

	T1	T2	B1	L1	L2	O/L	A/F
00192	3/8	3/8	3.18	12.17	27.94	48.26	0.625
00180	7/16	7/16	4.37	13.97	30.48	52.58	0.687
00181	1/2	1/2	5.94	13.97	30.48	52.58	19mm
00182	9/16	9/16	7.54	14.12	32.51	55.37	0.812
00183	3/4	3/4	9.93	16.69	36.58	61.98	1
00184	7/8	7/8	12.29	19.25	40.13	69.60	1.125
00185	1-1/16	1-1/16	15.47	21.95	44.45	78.49	1.375
00186	1-3/16	1-3/16	18.26	22.61	44.45	79.25	1.5
00187	1-5/16	1-5/16	21.44	23.14	44.45	79.76	41mm
00188	1-5/8	1-5/8	27.38	24.33	45.72	84.07	1.875
00189	1-7/8	1-7/8	33.32	27.51	45.97	89.41	55mm
00193	2-1/2	2-1/2	45.24	33.86	53.09	106.68	70mm