

All dimensions are imperial unless stated.

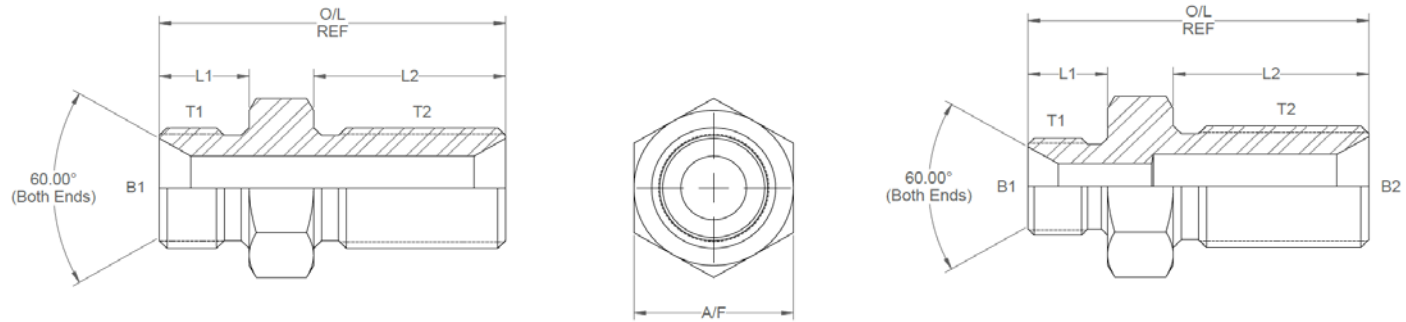

	T1	T2	B1	B2	L1	L2	O/L	A/F
00200	1/8	1/8	0.156		0.44	0.98	1.67	14mm
00201	1/4	1/4	0.234		0.45	1.04	1.76	19mm
00202	3/8	3/8	0.312		0.52	1.1	1.97	22mm
00203	1/2	1/2	0.437		0.6	1.28	2.31	27mm
00204	5/8	5/8	0.5		0.7	1.32	2.42	30mm
00205	3/4	3/4	0.625		0.75	1.32	2.4	32mm
00206	1	1	0.875		0.8	1.57	2.9	41mm
00207	1-1/4	1-1/4	1.125		0.8	1.57	2.9	50mm
00208	1-1/2	1-1/2	1.312		0.85	1.57	2.97	55mm
00209	2	2	1.719		1	1.57	3.17	70mm
00216	2-1/2	2-1/2	2.37		1	1.57	3.19	3.25
00217	3	3	2.75		1	1.57	3.19	95mm
00212	1/4	3/8	0.234	0.312	0.45	1.1	1.9	22mm
00223	1/4	1/2	0.234	0.437	0.45	1.28	2.18	27mm
00213	3/8	1/4	0.312	0.234	0.52	1.04	1.91	22mm
00211	3/8	1/2	0.312	0.437	0.52	1.28	2.23	27mm
00210	1/2	3/8	0.437	0.312	0.6	1.1	2.13	27mm
00222	1/2	5/8	0.437	0.5	0.6	1.32	2.32	30mm
00214	1/2	3/4	0.437	0.625	0.6	1.32	2.25	32mm
00215	3/4	1/2	0.625	0.437	0.75	1.28	2.36	32mm

DESIGN DETAILS AND SPECIFICATIONS SUBJECT TO CHANGE WITHOUT PRIOR NOTICE - Whilst every effort has been made to ensure the accuracy of the information supplied herein, Burnett & Hillman cannot be held responsible for any errors or omissions (E&OE)

All dimensions are imperial unless stated.

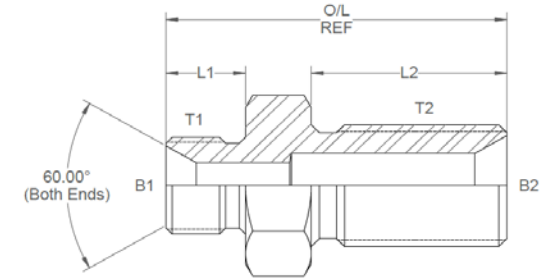
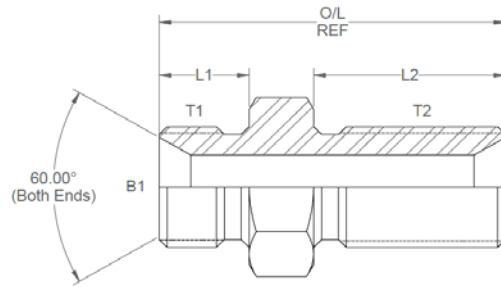

	T1	T2	B1	B2	L1	L2	O/L	A/F
00219	3/4	1	0.659	0.88	0.75	1.57	2.85	41mm
00220	1	3/4	0.843	0.63	0.80	1.32	2.65	41mm
00218	1	1-1/4	0.875	1.13	0.80	1.57	2.90	50mm
00224	1-1/4	1-1/2	1.125	1.31	0.80	1.57	2.92	55mm
00221	1-1/2	1	1.312	0.88	0.85	1.57	2.97	55mm

A/F dimensions are imperial unless stated.

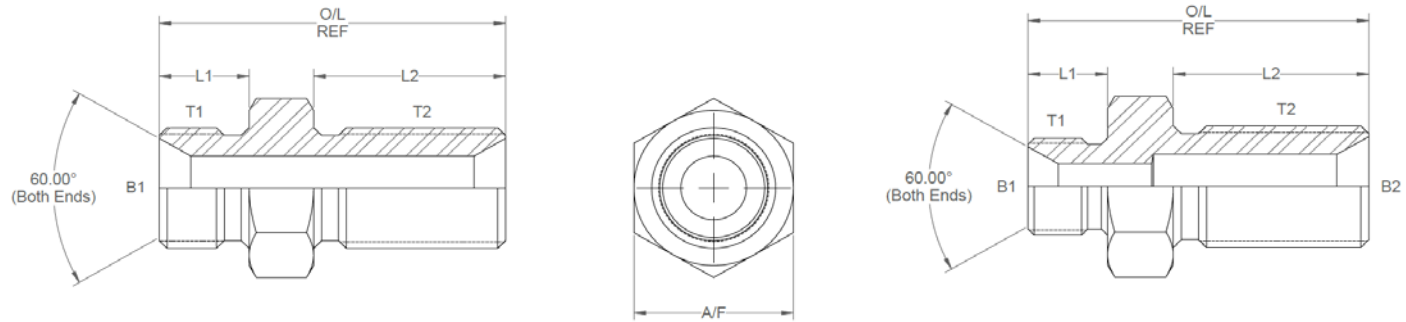

	T1	T2	B1	B2	L1	L2	O/L	A/F
00200	1/8	1/8	3.96		11.18	24.89	42.42	14mm
00201	1/4	1/4	5.94		11.43	26.42	44.70	19mm
00202	3/8	3/8	7.92		13.21	27.94	50.04	22mm
00203	1/2	1/2	11.1		15.24	32.51	58.67	27mm
00204	5/8	5/8	12.7		17.78	33.53	61.47	30mm
00205	3/4	3/4	15.88		19.05	33.53	60.96	32mm
00206	1	1	22.23		20.32	39.88	73.66	41mm
00207	1-1/4	1-1/4	28.58		20.32	39.88	73.66	50mm
00208	1-1/2	1-1/2	33.32		21.59	39.88	75.44	55mm
00209	2	2	43.66		25.40	39.88	80.52	70mm
00216	2-1/2	2-1/2	60.20		25.40	39.88	81.03	3.25
00217	3	3	69.85		25.40	39.88	81.03	95mm
00212	1/4	3/8	5.94	7.92	11.43	27.94	48.26	22mm
00223	1/4	1/2	5.94	11.10	11.43	32.51	55.37	27mm
00213	3/8	1/4	7.92	5.94	13.21	26.42	48.51	22mm
00211	3/8	1/2	7.92	11.10	13.21	32.51	56.64	27mm
00210	1/2	3/8	11.10	7.92	15.24	27.94	54.10	27mm
00222	1/2	5/8	11.10	12.70	15.24	33.53	58.93	30mm
00214	1/2	3/4	11.10	15.88	15.24	33.53	57.15	32mm
00215	3/4	1/2	15.88	11.10	19.05	32.51	59.94	32mm

DESIGN DETAILS AND SPECIFICATIONS SUBJECT TO CHANGE WITHOUT PRIOR NOTICE - Whilst every effort has been made to ensure the accuracy of the information supplied herein, Burnett & Hillman cannot be held responsible for any errors or omissions (E&OE)

A/F dimensions are imperial unless stated.

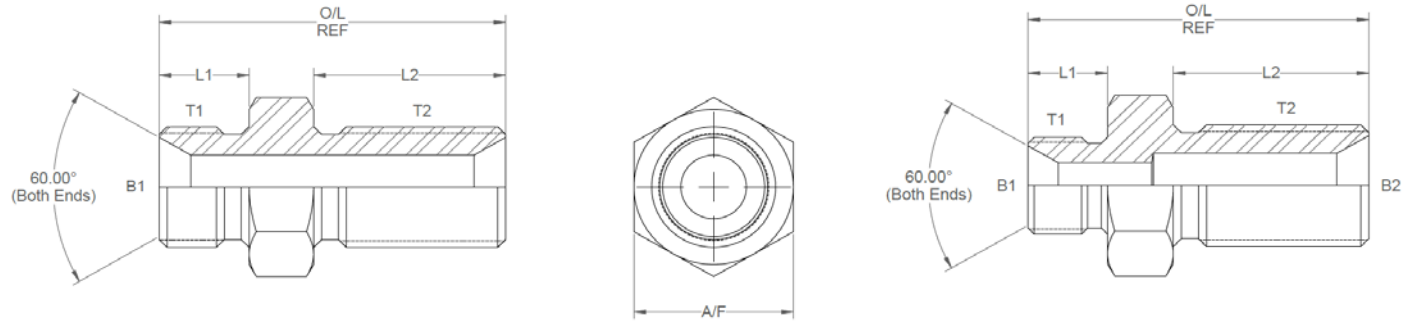

	T1	T2	B1	B2	L1	L2	O/L	A/F
00219	3/4	1	16.74	22.23	19.05	39.88	72.39	41mm
00220	1	3/4	21.41	15.88	20.32	33.53	67.31	41mm
00218	1	1-1/4	22.23	28.58	20.32	39.88	73.66	50mm
00224	1-1/4	1-1/2	28.58	33.32	20.32	39.88	74.17	55mm
00221	1-1/2	1	33.32	22.23	21.59	39.88	75.44	55mm